

BEECH OVENS™

WORLD LEADER IN SPECTACULAR COOKING EQUIPMENT



Shangri-La, Jakarta



Park Hyatt, Dubai



St Geran, Mauritius



Mandarin Oriental, Geneva



Sofitel, Brisbane

TANDOOR OVENS

Beech Ovens has been supplying spectacular cooking equipment to luxury restaurants and hotels world-wide since 1989.

The Beech Tandoor Oven is the world's most advanced tandoor oven and with a variety of shapes, sizes and finishes, is the tandoor of choice for leading chefs around the globe.

DESIGN SELECTION CRITERIA

Beech Ovens offers two styles of tandoor ovens, one has a ceramic cooking surface and the other has a mild steel cooking surface. The mild steel pot heats up quickly and is lightweight, while the ceramic internal pot is ideal for cooking traditional breads.

ACCESSORY & FINISH FEATURES

- 2 Sizes - option of 2 internal diameters 500mm & 700 mm
- 3 standard external shapes: round, square and barrel shaped
- Internal Pot - traditional ceramic or mild steel cooking surface
- Finish options including black, stainless, copper, terracotta or any colour
- 3 fuel types: charcoal, gas or electric
- Designed specifically for use in the luxury hotel environment
- Portable / transportable between venues
- Easy installation / removal
- Ready to operate - no further construction work required
- Supplied with analogue thermometer

DURABILITY FEATURES

- The first high technology tandoor; no longer is there a need to replace the internal pot yearly.
- Reinforced with steel bands to ensure normal thermal expansion will not compromise the structural integrity of the pot.
- Typical minimum wall thickness 75mm - twice the thickness of traditional Indian pots.
- Built in fire suppression system available.
- Fully insulated.
- Guaranteed for 12 months.

GAS CHARACTERISTICS

- Piezo ignition (easy and clean to light).
- Almost maintenance free.
- Reheats the tandoor quickly.
- No charcoal needs to be placed, nor ash removed.
- No solid fuel emission problems with regulatory authorities.
- Higher airflow through pot; slightly more difficult to cook with greater variations in pot temperature: hottest near burner.



500MM TANDOOR OVEN DRAWING

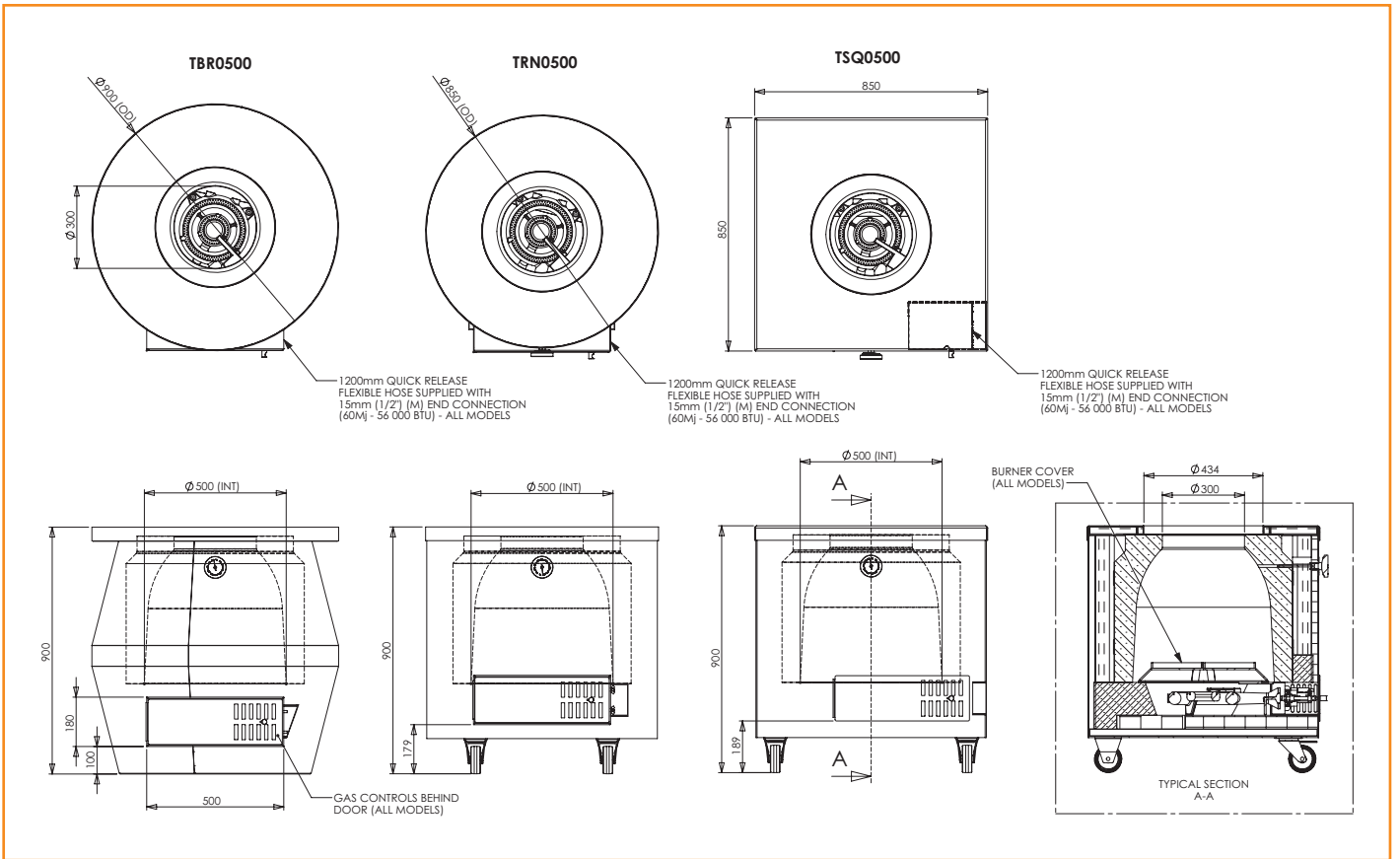

700MM TANDOOR OVEN DRAWING

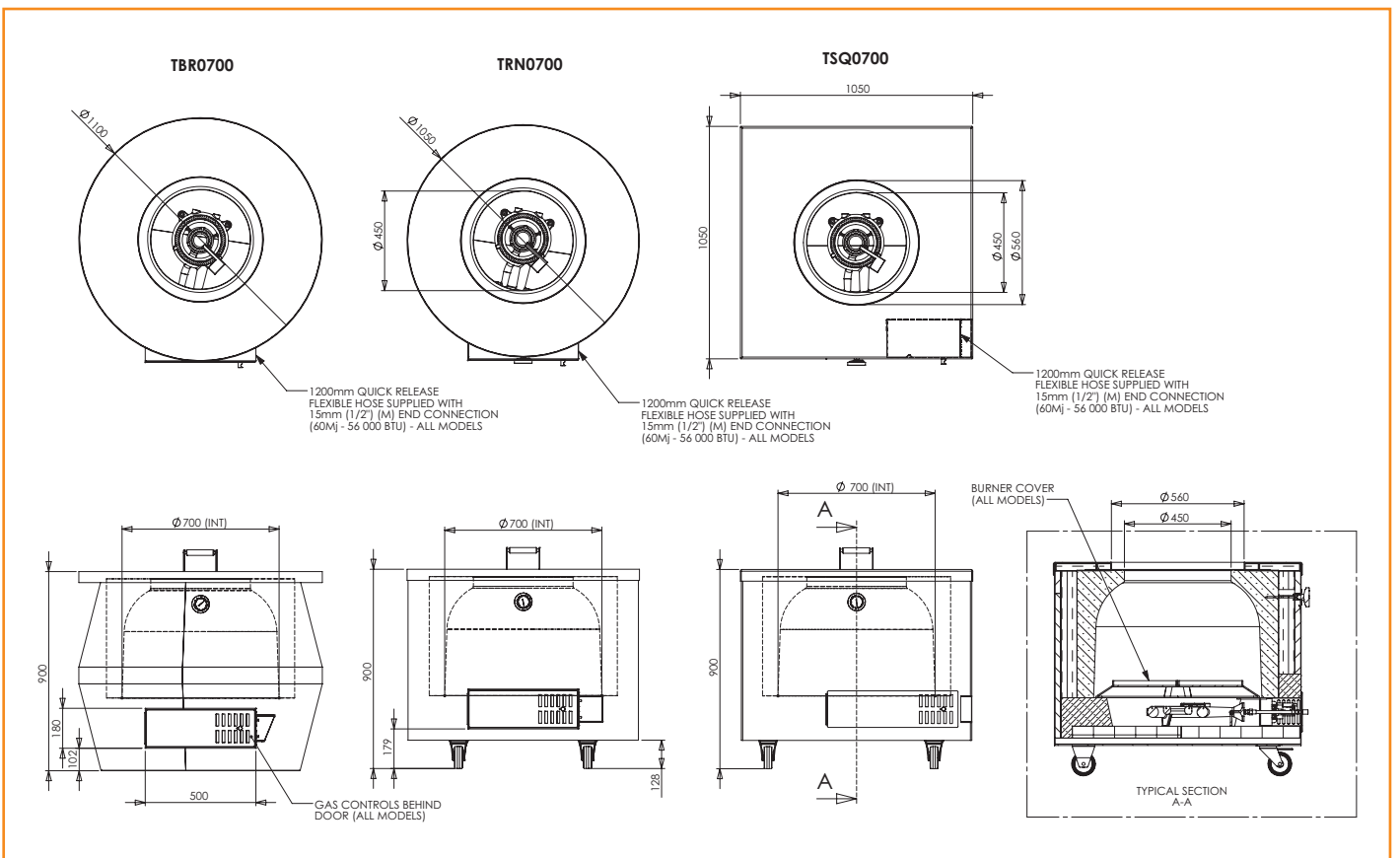

TANDOOR OVENS

SPECIFICATIONS

CE rated (Europe), USA 

MODEL	INTERNAL DIAMETER mm / inch	EXTERNAL DIAMETER mm / inch	HEIGHT mm / inch
TRN0500 (Round)	500mm / 20"	850mm / 34"	900mm / 36"
TSQ0500 (Square)	500mm / 20"	850mm / 34"	900mm / 36"
TBR0500 (Barrel)	500mm / 20"	900mm / 36"	900mm / 36"
TRN0700 (Round)	700mm / 28"	1050mm / 42"	900mm / 36"
TSQ0700 (Square)	700mm / 28"	1050mm / 42"	900mm / 36"
TBR0700 (Barrel)	700mm / 28"	1100mm / 43"	900mm / 36"

SERVICES

- Gas heat input 60Mj's. (56,000 BTU) 1/2" connection required.
- Electric tandoor - 380-450V 3Ph (no neutral).
- Approved canopy flue/ducting.

SUMMARY

The Beech Tandoor Oven is significantly different in design and quality to standard traditional tandoors.

The steel bands and advanced design provide strength to the outer casing.

The superior refractory material and manufacturing technique used to create the Beech Tandoor Oven ensures the longevity of the product. These tandoors do not require pots to be replaced - Beech has been supplying high quality tandoors for over ten years and has never replaced an internal pot.

The variety of finishes guarantees a spectacular impact.

It is for these reasons that Beech Ovens are the tandoor of choice for luxury hotels and restaurants worldwide.



TRN0500 (round)



TRN0700 (round)



TBR0500 (barrel)



TBR0700 (barrel)



TSQ0500 (square)



TSQ0700 (square)

All Beech Ovens documentation including Sales Material, Engineering and Architectural Information, Cooking Instructions and FAQ's is available on request in hard copy or digital format from Beech Head Office, or can be downloaded from our website www.beechovens.com.au.

www.beechovens.com

36 Gladys Street, Stones Corner, Queensland, Australia, 4120

Tel: (617) 3397 0277

Fax: (617) 3397 0030

e-Mail: sales@beechovens.com.au

Web: www.beechovens.com

ABN 14 115 371 741

BEECH OVENS  TM
WORLD LEADER IN SPECTACULAR COOKING EQUIPMENT

Ovens • Pizza • Tandoors • Bread • Duck Ovens • Char Grills • Rotisseries • Churrasco